

# EXPANDX

## USER MANUAL

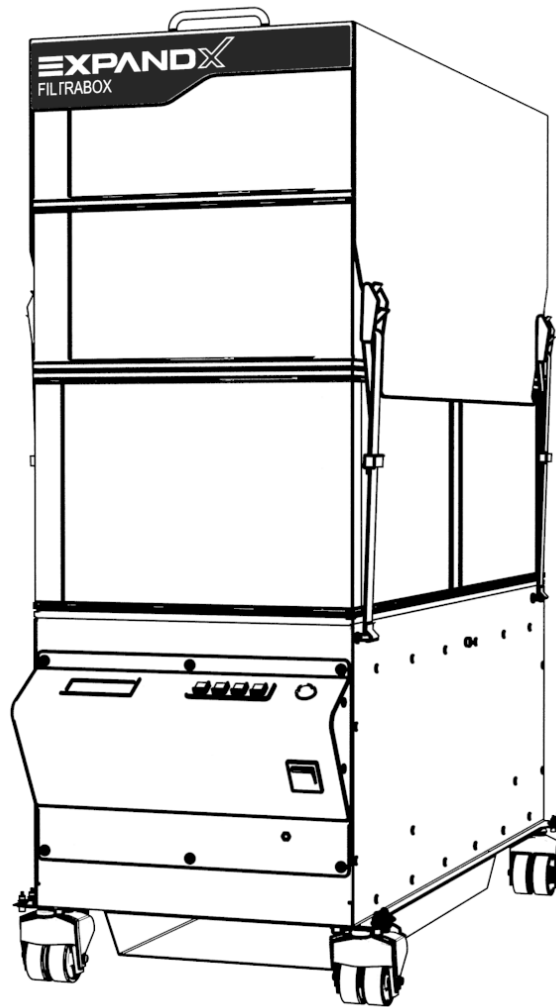

**FILTRABOX** 

**PAT Technology Systems Inc.**

3250 F.X Tessier, Vaudreuil-Dorion  
Quebec, Canada J7V 5V5

E-Mail: [info@filtrabox.com](mailto:info@filtrabox.com)

FOR SERVICE PHONE  
**1-888-655-8455**  
**514-840-9696**



# TABLE OF CONTENTS

- i. **INTRODUCTION** – pg. 3
- ii. **SPECIFICATIONS** – pg. 4
- iii. **MACHINE DIAGRAM** – pg. 5
- iv. **MACHINE DIAGRAM: USER INTERFACE** – pg. 6
- v. **MACHINE DIAGRAM: MODULES** – pg. 6
- vi. **ASSEMBLY INSTRUCTIONS** – pg. 7
- vii. **INSTALLATION INSTRUCTIONS** – pg. 8
- viii. **QUICK START INSTRUCTIONS**
  - a. CALIBRATION – pg. 9
  - b. AIRFLOW SETTING – pg. 10
- ix. **FILTER REPLACEMENT INSTRUCTIONS**
  - a. CHECK FILTER WARNING – pg. 12
  - b. FILTER CHECK FEATURE - pg. 13
  - c. REPLACING THE DUST PRE-FILTER – pg. 14
  - d. REPLACING THE HEPA DUST FILTER – pg. 14
  - e. OXY-CARBON GAS FILTER REPLACEMENT PROCEDURE – pg. 15
- x. **BLOWER MODULE REPLACEMENT** – pg. 16
- xi. **ELECTRONICS MODULE REPLACEMENT** – pg. 17
- xii. **UPGRADING TO EXPAND X-2** – pg. 18
- xiii. **SETTINGS**
  - a. OPERATING MODE – pg. 19
  - b. FILTER CHECK – pg. 20
  - c. SELECT # OF BLWRS – pg. 20
  - d. NEW APPLICATION CALIBRATION – pg. 20
  - e. SERVICE MENU – pg. 20
- xiv. **EZ-LINK CONTROLLER SET-UP AND PIN-OUT** - pg. 21
- xv. **SUPPORT** – pg. 23
- xvi. **WARRANTY** – pg. 24

# INTRODUCTION

Thank you for purchasing the premium engineered Filtrabox Fume extractor. Its modular construction allows for high performance, easy serviceability and longer life. In addition, the new "slim-line" design reduces the width of the extractor for the most efficient floor layouts.

**MICRO** is designed for the entry level laser user who wants a more economical solution yet still needs excellent performance and extreme space savings. The tiny, yet powerful digital Micro-Blower Module easily extracts dust and fumes from smaller laser applications, circulating the air through the filters and outputting the clean air back into the room.

**COMPACT X** is designed for laser users who need both compact dimensions and high performance for demanding substrates or volume production. Its single Blower Module easily extracts dust and fumes, circulating the air through the filters, outputting the clean air back into the room.

**EXPAND X-1** is designed for laser users who need more filter capacity as well as greater airflow for demanding substrates and higher volume production. Its single Blower Module easily extracts dust and fumes, circulating the air through the filters, outputting the clean air back into the room. The EXPAND X-1 also has a unique feature, made possible by our PATENT PENDING modular designs, which allows the EXPAND X-1 to be UPGRADED into an EXPANDX-2 simply by adding a Blower Module. The EXPAND X-1 can grow with your business!

**EXPAND X-2** is designed for laser users who need more filter capacity as well as extreme airflow for demanding substrates and commercial/industrial volume production. With 2 Blower Modules as standard equipment, the EXPANDX-2 can often be set-up to extract from two lasers simultaneously! Its dual Blower Modules easily extracts dust and fumes, circulating the air through the filters, outputting the clean air back into the room.

Servicing and maintaining the Filtrabox is a snap. The machine is made up of modular parts, making it easy for you to swap-out and swap-in any module by fastening a few screws and snapping a few cable connections per module.

# SPECIFICATIONS

	<b>Expand X1</b>	<b>Expand X2</b>
<b>Voltage</b>	120V / 240V	120V / 240V
<b>Frequency (Hz)</b>	50 / 60	50 / 60
<b>Wattage (kW)</b>	1.1	2.2
<b>Blower Type</b>	1x Brushless	2x Brushless
<b>Length (mm/inches)</b>	797.33 / 31.391	797.33 / 31.391
<b>Width (mm/inches)</b>	376.32 / 14.816	376.32 / 14.816
<b>Height (mm/inches)</b>	962.13 / 37.879	962.13 / 37.879
<b>Weight (kg/lbs)</b>	88/195	93/204
<b>Max Flow (CFM)</b>	235	470
<b>Pressure: (in. H<sub>2</sub>O)</b>	42 (High Pressure)	42 (High Pressure)
<b>Construction</b>	Steel	Steel
<b>Design</b>	Modular/Independent Filters	Modular/Independent Filters
<b>Operating Decibels</b>	50	50
<b>Display/Control</b>	LCD/Push Button	LCD/Push Button
<b>Flow Control</b>	Auto-Compensation	Auto-Compensation
<b>Warranty</b>	1 year	1 year
<b>Pre-Filter</b>	FIL-P-TX-428 Cylindrical Pre-Filter Media: F9 Glassfiber Filtration Area: 15m <sup>2</sup>	FIL-P-TX-428 Cylindrical Pre-Filter Media: F9 Glassfiber Filtration Area: 15m <sup>2</sup>
<b>HEPA Filter</b>	FIL-P-TX-418 Rigid Aluminum HEPA Filter Efficiency: 99.999% @ 0.3  Media: Glassfiber Filtration Area: 15m <sup>2</sup>	FIL-P-TX-418 Rigid Aluminum HEPA Filter Efficiency: 99.999% @ 0.3  Media: Glassfiber Filtration Area: 15m <sup>2</sup>
<b>Gas Filter</b>	FIL-G-TX-408 OXY-CARBON Filter Dual Action: Oxidation/Adsorption Carbon Weight: 80 lbs	FIL-G-TX-408 OXY-CARBON Filter Dual Action: Oxidation/Adsorption Carbon Weight: 80 lbs

# MACHINE DIAGRAM

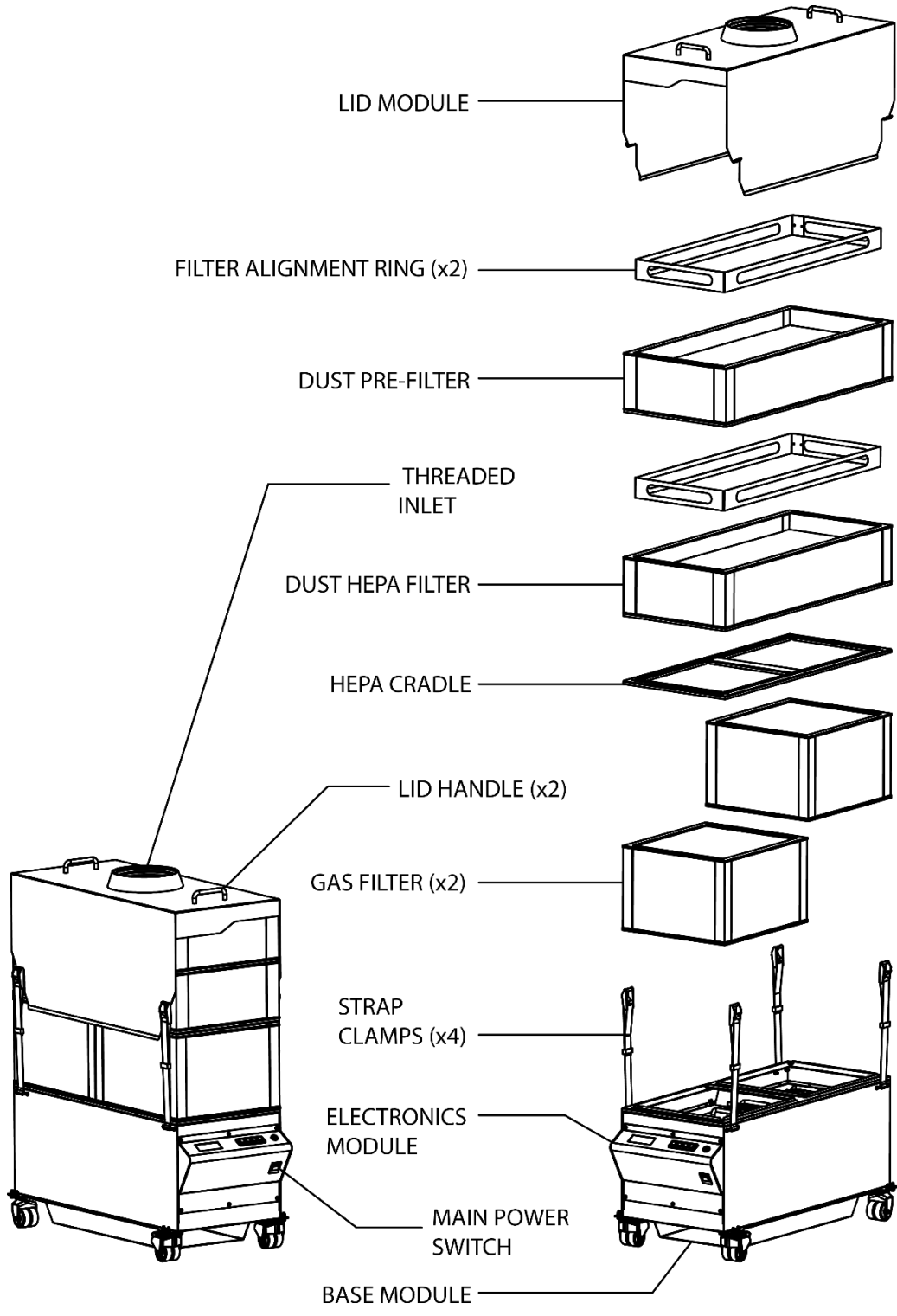

# MACHINE DIAGRAM – USER INTERFACE

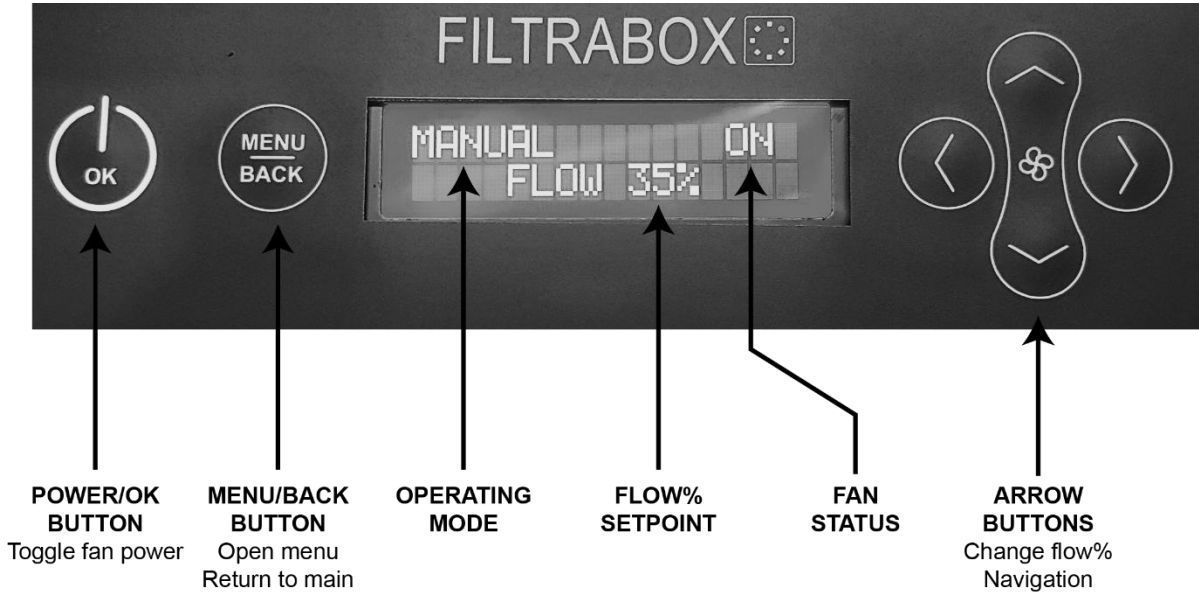

# MACHINE DIAGRAM – MODULES

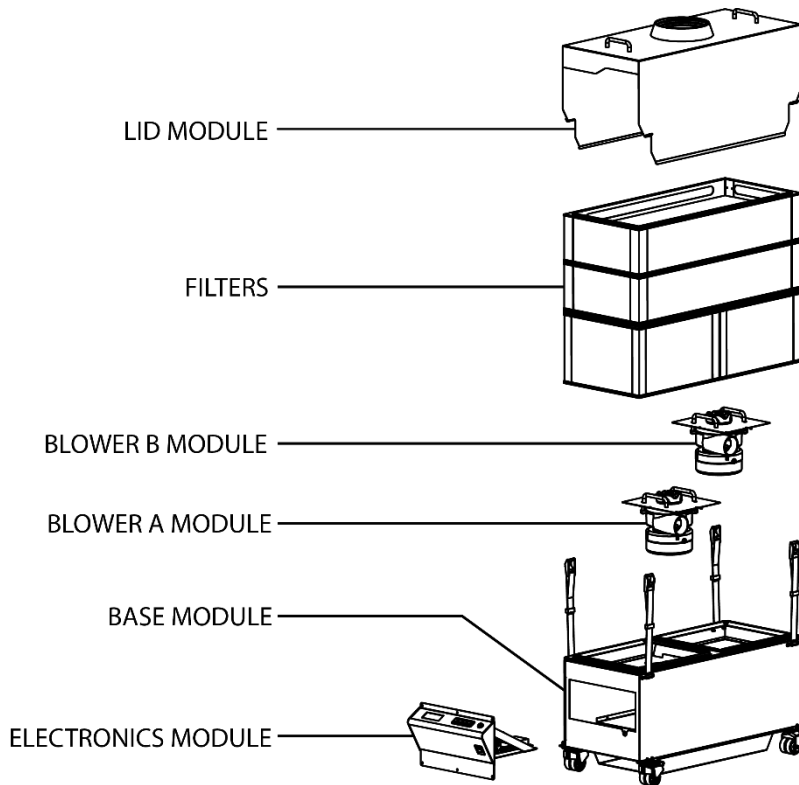

# ASSEMBLY INSTRUCTIONS

## UNPACKING

**! Useful Tip:** The Filtrabox is shipped in custom packaging for maximum protection during transport. Consider keeping the packaging should you wish to ship the product again.

**! Attention:** The OXY-Carbon Gas Filter is HEAVY. Each filter weighs approximately 50lbs each. Take appropriate care and precaution when lifting the filter.

Remove all the packaging and place all of the parts on the floor. Take inventory of the parts included with your kit:

- 1. Main Chassis + Blower Module(s) (Pre-Installed)**
- 2. Dust Pre-Filter**
- 3. HEPA Dust Filter**
- 4. OXY-Carbon Gas Filter Set**
- 5. Lid Module**
- 6. Threaded Inlet Adapter: designed to fit the with included 6" flex hose**
- 7. Flex Hose: 6" diameter x 8 feet with hose clamp**
  - a. Other hose adapters are optional**
- 8. Power Cord: rated to 20 amps**



# INSTALLATION INSTRUCTIONS

**! Important Note: The Calibration system will take all the bends and restrictions of the flex hose into account and provide optimal performance.**

1. Screw the supplied **6" Flex Hose** onto the inlet of the machine. Insert the hose into the threads and turn anti-clockwise until it can longer turn. See figure below.
2. Secure the other end of the supplied **6" Flex Hose** to your laser with the supplied **Hose Clamp**.
3. Place the Filtrabox in the final position that it will be regularly used. This is important for **Calibration** as the system will take all the bends and flow restrictions of the flex hose into account and provide optimal performance. Engage the brakes on the two front wheels to hold the machine in place.
4. Install the supplied power cord onto the back of the Filtrabox and turn it on with the **Main Power Switch** located on the bottom of the **User Interface**.

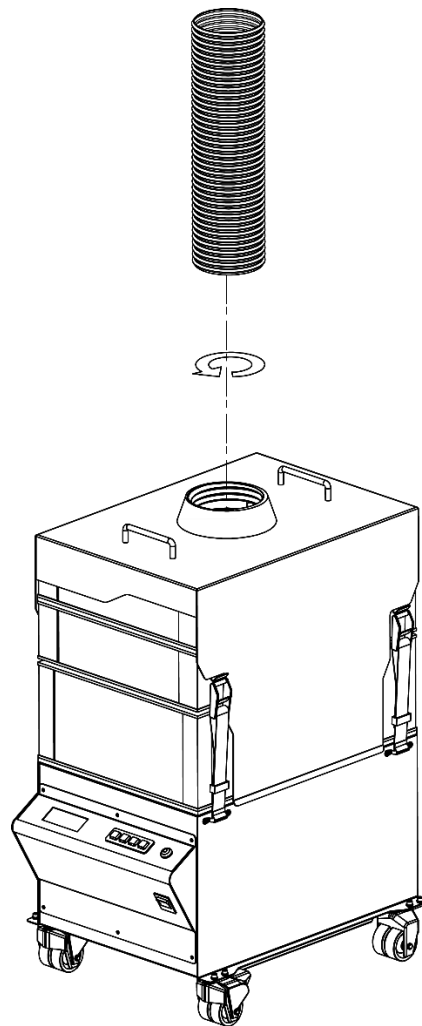

# QUICK START INSTRUCTIONS:

## CALIBRATION & AIRFLOW SETTING

### SAFETY

***! Before connecting the device to a power source, ensure that the main power switch in the rear of the device is in the off position “0”.***

***! Avoid plugging or unplugging the unit while it is powered ON ( “I” ).***

### CALIBRATION

***! Device must be calibrated to your specific laser engraver to function properly.***

***! Failure to calibrate the device prior to usage may significantly reduce the life of your filters.***

1. Hook up the Filtrabox fume extractor to the Laser Engraver, with the supplied hose or with the hose you intend to permanently use for the application. Arrange the laser, Filtrabox and the hoses into their desired locations. ***! This is important because the calibration process takes the restrictions caused by the bends in the hose and positioning of the equipment into account.***

***! EXPAND X has 1 or up to 3 blowers. This is important to know before calibrating your device. Check your device to confirm the number of blowers installed. See the sticker on the front of the machine.***

2. While on the “# OF BLOWERS” screen, select the number of blowers by pressing the up or down arrows accordingly. Confirm your selection by pressing the “OK” button. The screen will then prompt to “PRESS OK TO CALIBRATE”, press the “OK” button to continue.  
***! This will automatically trigger the Calibration process which will take approximately one minute. If you have selected the wrong number of blowers, the calibration process will fail and the system will have to be rebooted and restarted.***
3. If you have previously set the number of blowers and wish only to Calibrate Filtrabox to a new application, press the “Menu” button. Press the right arrow key to advance the screen until you reach the “New Application Calibration” section. Press the “OK” button to initiate Calibration. ***The Calibration process will take approximately one minute. If you have selected the wrong number of blowers, the calibration process will fail and the system will have to be rebooted and the process restarted.***

## **AIRFLOW % SETTING**

***! USEFUL TIP 1:*** Use the “4-6 second rule” to determine adequate evacuation of the laser; the “**Airflow %**” setting should be set to the value where you can observe full evacuation of the fumes from the laser enclosure within 4-6 seconds from the instant that the laser stops engraving/cutting. Check by opening the laser top cover 4-6 seconds after the laser stops. There should NOT be any fumes visible. If you cannot achieve the 4-6 second rule, you can try the 6-8 second rule, which is also acceptable.

Set your “**Airflow %**” to the lowest possible setting that will adequately evacuate the fumes from your laser. This ensures that you are using your filters to their maximum potential which minimizes costs.

***! USEFUL TIP 2:*** Start by setting your Filtrabox at 15% for a small sized laser or 25% for a medium sized laser, or 40% for a large sized laser and incrementally increase up from those starting points, using the 4-6 second rule to determine the minimum adequate evacuation setting.

## **SETTING THE AIRFLOW% SETTING**

1. The Status screen is the first screen shown once the device has finished calibrating or finished booting up. The device will display the current flow setting.
2. Turn on the blower by pressing the “**Power**” button while in the “**MANUAL**” setting.
3. Set the “**Airflow %**” to the desired starting point by pressing the “**UP**” or “**Down**” buttons.

***! USEFUL REMINDER:*** Start by setting your Filtrabox at 15% for a small sized laser or 25% for a medium sized laser, or 40% for a large sized laser and incrementally increase up from those starting points, using the 4-6 second rule to determine the minimum adequate evacuation setting.

4. Start engraving/cutting on the most smoke/odor generating substrate you will typically use.
5. Adjust the “**Airflow %**” until you see significant movement of the fumes towards the laser intake vents.
6. Check to see if you have achieved the adequate evacuation flow using the 4-6 second rule or the 6-8 second rule.
7. Continue adjusting your flow until you are satisfied with the performance. The “**Airflow %**” value will be automatically saved to memory.

***! The AUTO-COMPENSATION FLOW CONTROL feature, which is standard on the Filtrabox, will maintain the set-point “Airflow %” by automatically increasing power to the blowers as the filters get obstructed by the dust. You do not have to manually change the “Airflow %” setting again – unless you change your laser or use a more fume generating substrate. Note: “Airflow %” represents the Airflow potential of your system.***

8. When the laser is not in use, press the “**Power**” button to turn the blower(s) off.
9. Filtrabox has an EZ-link feature that allows you to turn the blowers ON or OFF remotely from the laser (if this feature is available on your laser). See the EZ-LINK section of the manual.

**YOUR FILTRABOX LASER EXTRACTOR IS  
NOW SET-UP FOR OPERATION.**

# FILTER REPLACEMENT INSTRUCTIONS

**! When the “Check Filter” warning comes on, increasing the “Airflow %” value WILL NOT increase actual airflow. The “Check Filter” warning indicates that the “Airflow %” set-point can no longer be achieved despite the fact that the power applied to the blower by the “AUTO-COMPENSATION FLOW CONTROL” feature is at maximum value. This is most likely due to airflow blockage in the Pre-filter or HEPA filter from normal usage.**

The Filtrabox Expand X system has 3 types of filters; Pre-Filter, HEPA filter and OXY-Carbon Filters.

1. **Pre-Filter FIL-P-TX-428:** Collects fine dust
2. **HEPA Filter FIL-P-TX-418:** Collects ultra-fine dust
3. **OXY-Carbon Filter Set FIL-G-TX-408:** Adsorbs and destroys odor causing gases.

All three filters will need to be independently replaced at some point in time during the course of normal usage.

## **“CHECK FILTER” WARNING**

**! Replacement filters can be purchased from: [info@filtrabox.com](mailto:info@filtrabox.com) or call 514.840.9696 ext. 102**

The “**Check Filter**” warning will appear on the screen when either Dust filters (Pre-Filter and/or the HEPA) filter need replacement.

When the “**Check Filter**” warning comes on, increasing the “**Airflow %**” value WILL NOT increase actual airflow. The “**Check Filter**” warning indicates that the “**Airflow %**” set-point can no longer be achieved despite the fact that the power applied to the blower by the “**Dynamic Flow Control**” feature is at maximum value. This is most likely due to airflow blockage in the Pre-filter or HEPA filter from normal usage.

## “FILTER CHECK” FEATURE

**! Useful Tip: Check for obstructions in the hose before ordering a new filter. An obstruction in the hose may cause an erroneous “CHECK FILTER” WARNINGS.**

**! The Pre-Filter captures the majority of dust generated by the laser. Therefore, it is the most frequently replaced dust filter in the system.**

**! Replacement filters can be purchased from your dealer or: [info@filtrabox.com](mailto:info@filtrabox.com) or call 514.840.9696 ext. 102**

1. If the “**CHECK FILTER**” warning comes on, go to the **User Interface** and press the “**Menu**” button. Press the “**left or right arrow**” button to scroll through the menu functions until you find the “**CHECK FILTER**” feature.
2. Press the “**OK**” button to initiate the “**CHECK FILTER**” process.
3. Filtrabox will assess the status of **all the Dust Filters** in your systems and then prompt you to remove **the Pre-Filter**. Follow the instructions on the screen.
4. To remove the **Pre-Filter** first loosen all four **Strap Clamps** on the **Lid**, then unhook the **Strap Clamps** and pull the lid straight up by the two **Handles**.
5. Remove the topmost **Filter Alignment Ring** and the **Pre-Filter** and set them aside, then put the **Lid** back onto the **HEPA Filter** as in the image below. Hook the **Strap Clamps** back onto to the **Lid** and ensure that they are tight.
6. Follow the prompt on screen and press the **Enter Button** to continue.
7. Filtrabox will then advise you to replace **either the HEPA or the Pre-Filter** depending on their actual conditions. Or, the system will advise you to consider upgrading to a more powerful model if the Airflow% setting is too high, which would cause the filters to be inefficiently used (causing frequent filter changes).
8. When the filter check is complete, replace the **Pre-Filter** and the topmost **Filter Alignment Ring** making sure that the **Strap Clamps** are tightened.

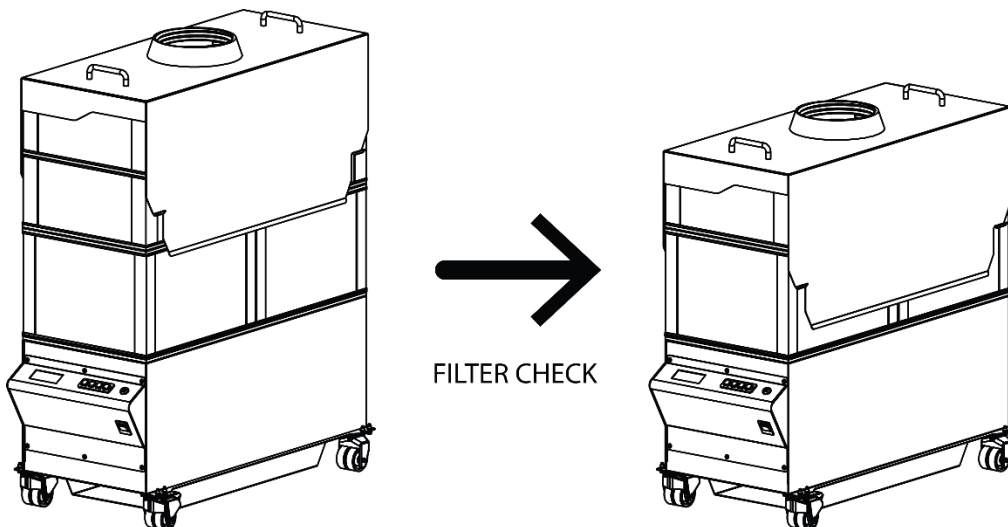

## **REPLACING THE DUST PRE-FILTER**

**FIL-P-TX-428**

**! Replacement filters can be purchased from your dealer or: [info@filtrabox.com](mailto:info@filtrabox.com) or call 514.840.9696 ext. 102**

**! Important Note: The Filter Alignment Rings must be centered correctly into each filter. They should fit inside both filters when installed correctly.**

**! To avoid any risk of electrical discharge, turn off and unplug the Filtrabox before doing any activities that require disassembly of the unit.**

1. Loosen all four **Strap Clamps** on the **Lid** by pressing the lever on the clamps. Unhook the **Strap Clamps** and remove the **Lid** by lifting it straight up off the assembly.
2. Set aside the topmost **Filter Alignment Ring**.
3. Remove and replace the old **Pre-Filter** and ensure that the new one is centered correctly onto the **HEPA Filter** and that it is oriented the right way up on the next **Filter Alignment Ring**.
4. Ensure that the new **Pre-Filter** is the right side up by following the label.
5. Replace the topmost **Filter Alignment Ring** that was set aside earlier onto the new **Pre-Filter**.
6. Replace the **Lid** back onto the machine and tighten all four **Strap Clamps** back onto the hooks.
7. Check the **Machine Diagram** on page 4 if necessary.

## **REPLACING THE HEPA DUST FILTER**

**FIL-P-TX-418**

**! Replacement filters can be purchased from your dealer or: [info@filtrabox.com](mailto:info@filtrabox.com) or call 514.840.9696 ext. 102**

**! Important Note: The Filter Alignment Rings must be centered correctly into each filter. They should fit inside both filters when installed correctly.**

**! To avoid any risk of electrical discharge, turn off and unplug the Filtrabox before doing any activities that require disassembly of the unit.**

1. Loosen all four **Strap Clamps** on the **Lid** by pressing the lever on the clamps. Unhook the **Strap Clamps** and remove the **Lid** by lifting it straight up off the assembly.
2. Set aside the topmost **Filter Alignment Ring**, the **Pre-Filter**, and the next **Filter Alignment Ring**.
3. Remove and replace the old **HEPA Filter** and ensure that the new one is centered correctly onto the **HEPA Cradle** and that it is oriented the right way up.
4. Replace one of the **Filter Alignment Rings** (they are all the same) that was set aside earlier onto the new **HEPA Filter**.
5. Replace the **Pre-Filter** and the topmost **Filter Alignment Ring** that were set aside earlier onto the new **HEPA Filter** as well.
6. Ensure that the new **HEPA Filter** and **Pre-Filter** are the right side up by following the labels.
7. Replace the **Lid** back onto the machine and tighten all four **Strap Clamps** back onto the hooks.
8. Check the **Machine Diagram** on page 4 if necessary.

## **REPLACING THE OXY-CARBON GAS FILTERS**

**FIL-G-TX-408**

**! Replacement filters can be purchased from your dealer or: [info@filtrabox.com](mailto:info@filtrabox.com) or call 514.840.9696 ext. 102**

**! When laser odor becomes evident, it is time to change the GAS FILTERS.**

**! To avoid any risk of electrical discharge, turn off and unplug the Filtrabox before doing any activities that require disassembly of the unit.**

**! Attention: The OXY-Carbon Gas Filters are HEAVY. Each filter weighs approximately 50lbs. Take appropriate care and precaution when lifting the filters.**

1. Loosen all four **Strap Clamps** on the **Lid** by pressing the lever on the clamps. Unhook the **Strap Clamps** and remove the **Lid** by lifting it straight up off the assembly.
2. Set aside the three **Filter Alignment Rings**, the **Pre-Filter**, the **HEPA Cradle** and the **HEPA Filter**.
3. Remove and replace the old **Gas Filters** and ensure that the new ones are centered correctly onto the **Base Module**.
4. Replace the **HEPA Cradle** that was set aside earlier onto the new **Gas Filters** and ensure that it is oriented the right way up.
5. Replace the **HEPA Filter** and the next **Filter Alignment Ring** that were set aside earlier onto the new **Gas Filter** and that it is oriented the right way up.
6. Replace the **Pre-Filter** and the topmost **Filter Alignment Ring** that were set aside earlier onto the **HEPA Filter** and ensure that it is oriented the right way up.
7. Ensure that **all the Filters** are the right side up by following the labels.
8. Replace the **Lid** back onto the machine and tighten all four **Strap Clamps** back onto the hooks.
9. Check the **Machine Diagram** on page 4 if necessary.



# BLOWER MODULE REPLACEMENT

**! To avoid any risk of electrical discharge, turn off and unplug the Filtrabox before doing any activities that require disassembly of the unit.**

**! Replacement modules can be purchased from your dealer or: [info@filtrabox.com](mailto:info@filtrabox.com) or call 514.840.9696 ext. 102**

The Expand X comes standard with one or two Blower Modules that can be easily replaced by removing a few screws and disconnecting/connecting two cables.

1. **!IMPORTANT!** Ensure that the Filtrabox is powered off and unplugged.
2. Loosen all four **Strap Clamps** on the **Lid** by pressing the lever on the clamps. Unhook the **Strap Clamps** and remove the **Lid** by lifting it straight up off the assembly.
3. Remove all three filters and all three **Filter Alignment Rings** between them; set these parts aside.
4. Remove the **Carbon Filter Cradle** from the **Base Module** and set it aside (see image below)
5. Unplug the **Fan Sensor** plug from its socket on the top of the machine.
6. Remove all eight Phillip's-head screws holding down the **Blower Module**.
7. Pull up the **Blower Module** by the two handles and unplug the wire harness on the module. Once unplugged, the old blower module can be removed.
8. Plug in the wire harness for the new module then insert it into the machine.
9. Screw the eight Phillip's-head screws back in.
10. Plug in the new **Fan Sensor**.
11. Reinstall the **Carbon Filter Cradle** ensuring that it is centered over the machine.
12. Reinstall all the filters and the lid with all four **Strap Clamps** as it was before. Refer to the **Machine Diagram** on page 4 if necessary.
13. Plug in and power-on the unit, then go to the **User Interface** and press the **"Menu"** button. Press the right arrow key to advance the screen until you reach the **"New Application Calibration"** section. Press the **"OK"** button to initiate Calibration. **The Calibration process will take approximately one minute..**

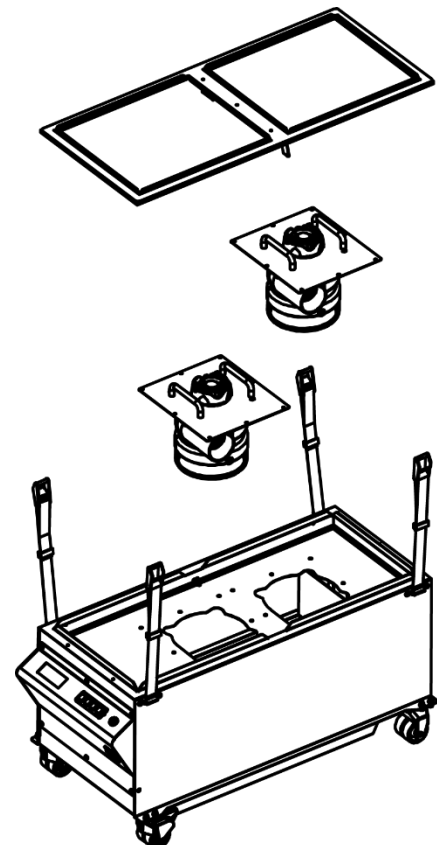

# ELECTRONICS MODULE REPLACEMENT

**! To avoid any risk of electrical discharge, turn off and unplug the Filtrabox before doing any activities that require disassembly of the unit.**

The **Electronics Module** houses all the main electrical components and the main electronics assemblies. In the event of damage or a malfunction, the entire module can be removed from Filtrabox by removing a few screws and disconnecting a few cables. Contact Filtrabox to order.

1. **!IMPORTANT!** Ensure that the Filtrabox is powered off and unplugged.
2. Remove all six Phillip's-head screws holding the **Electronics Module** in place.
3. Pull the **Electronics Module** out and place it on the floor in front of the machine with all the wires still connected.
4. Disconnect all seven wires that connect the **Electronics Module** to the rest of the machine:
  - a. The two large white 5-pin connectors (mark these to orient them correctly later)
  - b. The two wires on the power switch
  - c. The ribbon cable on the main board
  - d. The two small 2-pin JST connectors (mark these to orient them correctly later)
5. Remove the old **Electronics Module** and replace it with the new one by reconnecting the wires that were disconnected in step 4.
6. Insert the new module into the machine and reuse the six Phillip's-head screws to hold it in place.
14. Plug in and power-on the unit, then go to the **User Interface** and press the **"Menu"** button. Press the right arrow key to advance the screen until you reach the **"New Application Calibration"** section. Press the **"OK"** button to initiate Calibration. **The Calibration process will take approximately one minute.**

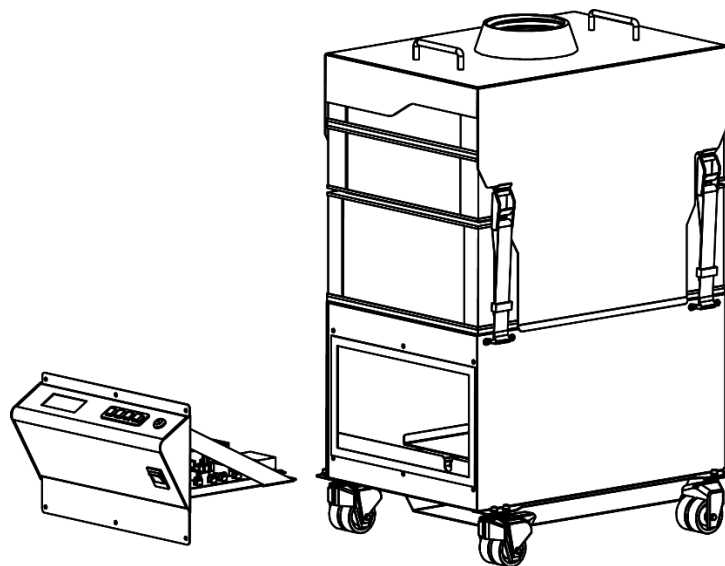

# UPGRADING TO EXPAND X-2

**! To avoid any risk of electrical discharge, turn off and unplug the Filtrabox before doing any activities that require disassembly of the unit.**

*Expand X-1* comes standard with **1 Blower Module** that can easily be upgraded to function with **2 Blower Modules** as an *Expand X-2* for maximum performance and increased dust capacity. Contact Filtrabox to order.

1. **!IMPORTANT!** Ensure that the Filtrabox is powered off and unplugged.
2. Loosen all four **Strap Clamps** on the **Lid** by pressing the lever on the clamps. Unhook the **Strap Clamps** and remove the **Lid** by lifting it straight up off the assembly.
3. Remove all three filters and all three **Filter Alignment Rings** between them; set these parts aside.
4. Remove the **Carbon Filter Cradle** from the **Base Module** and set it aside (see image below)
5. Remove all eight Phillip's-head screws holding down the **Dummy Blower Module**.
6. Pull up and remove the **Dummy Blower Module** by the two handles.
7. Plug in the wire harness for the new module then insert it into the machine.
8. Screw the eight Phillip's-head screws back in.
9. Plug in the new **Fan Sensor**.
10. Reinstall the **Carbon Filter Cradle** ensuring that it is centered over the machine.
11. Reinstall all the filters and the lid with all four **Strap Clamps** as it was before. Refer to the **Machine Diagram** on page 4 if necessary.
12. Plug in and power-on the unit, then go to the **User Interface** and press the **"Menu"** button. Press the **"Left or Right"** buttons until you reach **"Set # of Blwrs"** on the screen. Press the **"OK"** button. Press the **"Up or Down"** arrow keys to select 2 blowers. The **Calibration** sequence will self-initiate. **Calibration** cannot be interrupted.

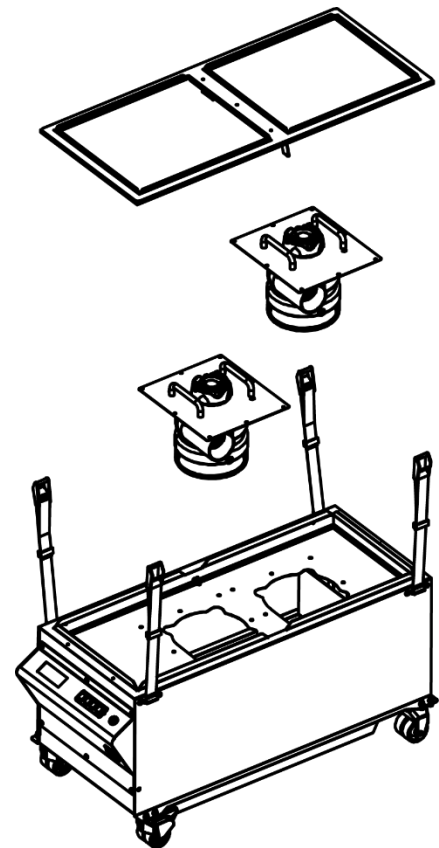

# SETTINGS

Press the “Menu” button and then use the “Left or Right” buttons to scroll through the settings menus. Press the “OK” button to select the setting:

## OPERATING MODE SETTING

There are **3 Modes of Operation**. In all three modes, the user always controls the “**Airflow %**” setting by simply pushing the “UP or Down” buttons at any time. To select the mode, press the “Up or Down” arrows to scroll the options below and press the “OK” button to confirm your selection.

### 1. Manual Mode (On/Off)

This mode allows the user to manually choose the on/off state of the blowers in the Filtrabox. This is the default mode. Toggle “**ON/OFF**” by pressing the “**Power**” arrow key. The blower(s) will be engaged to the previously set “**Airflow %**”

### 2. Link On/Off

This mode uses the **DB9 connection** at the rear of the Filtrabox. The blowers will be engaged at the previously set “**Airflow %**” when Laser requests it. (If feature is available on the Laser.) When the Laser does not require any airflow, the system automatically deactivates the blowers. If there is no laser system connected, the blowers will never engage. See the Controller Set-up and Pin-Out example at the end of the manual.

### 3. Link On/Idle

This mode uses the **DB9 connection** at the rear of the Filtrabox. The blowers will be engaged at the previously set “**Airflow %**” when Laser requests it. (If feature is available on the Laser.) When the Laser system does not require operating airflow, the system continues **idle** at a very low setting to contain fumes from the off-gassing of lasered materials, and off-gassing of dust in the Filtrabox or the Laser enclosure. See the Controller Set-up and Pin-Out example at the end of the manual.

## **FILTER CHECK** SETTING

See the *FILTER CHECK Feature* in *Filter Replacement Instructions*.

## **SELECT # OF BLWRS** SETTING

**! This setting should only be used when initially setting up the machine or when upgrading from a single blower set-up to a dual blower set-up. Pressing the “OK” button while in this setting will automatically set the machine into the Calibration sequence once the # of blowers has been selected. Avoid doing this unnecessarily.**

While in the *“SELECT # OF BLWRS”*s setting. Press the *“Up or Down”* arrow keys to toggle between **1 or 2 blowers**. Press the *“OK”* button to confirm your selection. Calibration will automatically initiate.

## **NEW APPLICATION CALIBRATION** SETTING

**! This will initiate the Calibration sequence. Avoid doing this unnecessarily.** This should only be used if you are changing lasers, length of hose, diameter of hose; or anything that would change (reduce or increase) the airflow restrictions in the entire system. Calibration should only be done with a new set of filters otherwise the filter check feature will not function as intended.

While in the *“New Application Calibration”* setting, press the *“OK”* button to initiate Calibration. ***The Calibration process will take approximately one minute. If you have selected the wrong number of blowers, the calibration process will fail and the system will have to be rebooted and the process restarted.***

## **SERVICE MENU** SETTING

This menu is only to be used by Filtrabox Technicians or with the guidance of a Filtrabox Technician.

# EZ-LINK CONTROLLER SET-UP AND PIN-OUT

## DB9 PIN-OUT

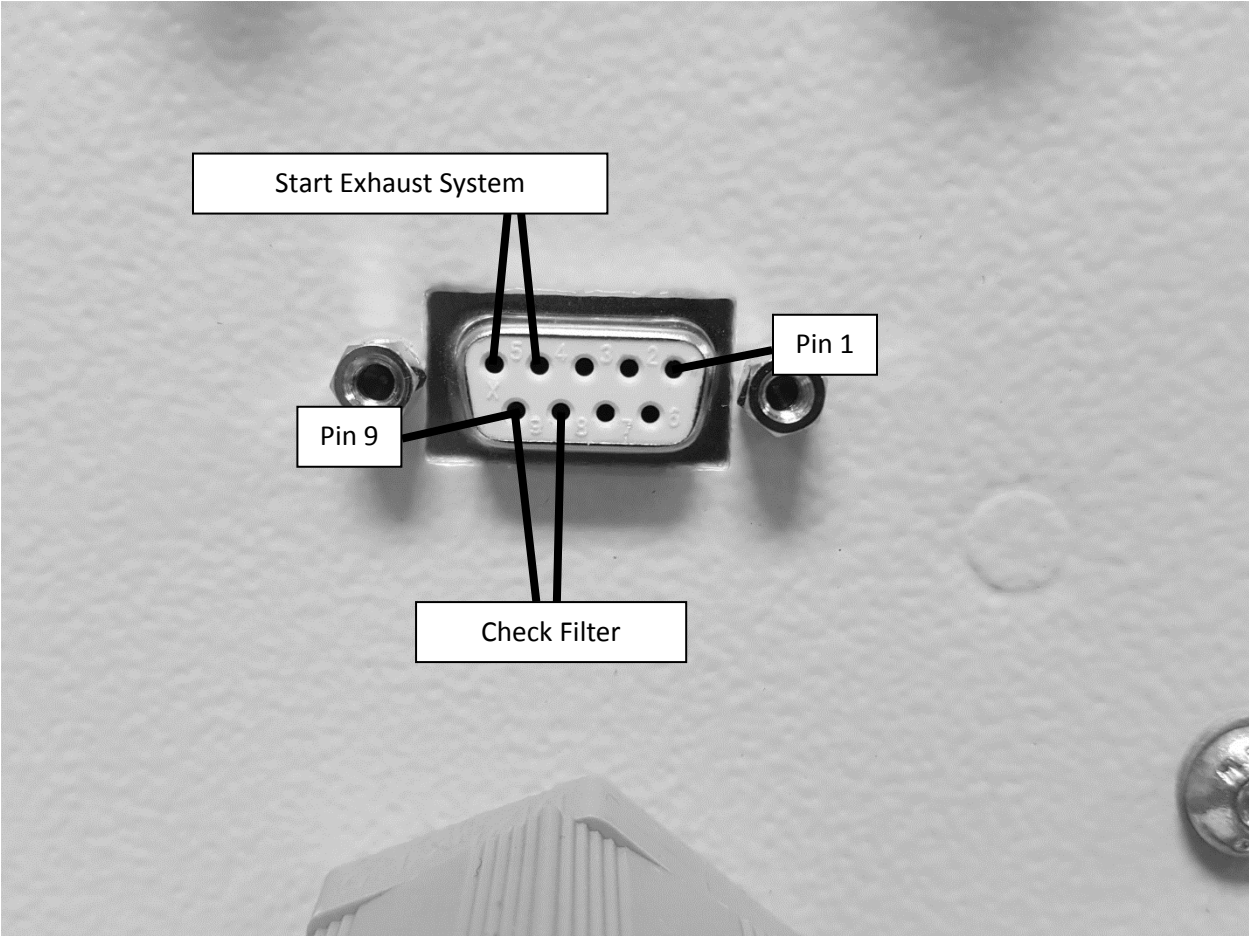

**Figure 1: An example of a D-Sub 9 connector**

**Pins 4 & 5:** Normally Open – Output from Laser Controller

The controller connects these two pins to start the exhaust system.

**Pins 8 & 9:** Normally Open – Input to Laser Controller

The exhaust system should connect these two pins when the filter check status appears on the extractor.

## EZ-LINK Electrical Requirements

Figure 2 below shows the required circuit for the output on the laser's filter control system. When the laser's filter control unit wishes to turn on the exhaust system, the contacts on the relay are closed, thus connecting the two output pins. These output pins correspond to pins 4 & 5 on the exhaust system. When creating a circuit to detect when these two wires have been connected, **no more than 200 mA** may pass through these wires.

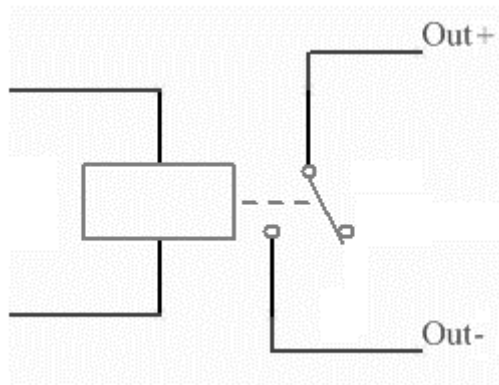

**Figure 2: The circuit for the "start exhaust system" signal.**

When creating the "Check Filter" signal, the two wires for the signal should be shorted together using a relay. This means that the exhaust system will not actively dump any current through these wires. The laser's filter control unit should use approximately 30 mA to detect when those wires have been connected.

## EZ-LINK Control Operations

The filter control operation is very simple. When a user begins to run a laser engraving/cutting job, the filter controller turns on the exhaust system immediately. When the job has been cancelled, paused, or finished, the laser's filter control unit should wait 15 seconds or more before turning off the exhaust system. This allows any extra fumes to be evacuated from the laser engraver.

# SUPPORT

For any and all questions related to our Filtrabox products and accessories, please do contact us anytime. It will be our pleasure to make fume extraction easier and more effective for any of your applications.

Please contact us through: [info@filtrabox.com](mailto:info@filtrabox.com) or call 514.840.9696 ext. 102

**FILTRABOX** 

**PAT Technology Systems Inc.**

3250 F.X Tessier, Vaudreuil-Dorion

Quebec, Canada J7V 5V5

E-Mail: [info@filtrabox.com](mailto:info@filtrabox.com)

FOR SERVICE PHONE

**1-888-655-8455**  
**514-840-9696**



# WARRANTY

1 Goods manufactured by PAT: PAT warrants that the Goods manufactured by it will be free from defects in materials and workmanship for a period of 12 months from the date of *item receipt*.

Exceptions:

Spare parts including replacement filters: 1 month from installation.

Used and ex-demonstration equipment: 1 month from installation.

In the case of any breach of warranty then PAT shall at its option remedy such defects or refund such sums as the Purchaser has paid to PAT in respect of such Goods. PAT shall be under no liability under the above warranties:

1.1 arising from any drawing, design or specification supplied by the Purchaser;

1.2 arising from improper installation, storage, use, modification or operation including but not limited to the use of consumable items not approved by PAT;

2 Goods manufactured by third parties : PAT will use its best endeavours to obtain for the purchaser the benefit of any warranty provided by the original manufacturer of the Goods. Repair or replacement, in whole or in part, of Goods which fail due to faulty manufacture is available from the original manufacturer under its warranty. PAT must be consulted to approve the return of Goods for replacement or repair under the original manufacturer's warranty.

3 All replacement items will be charged at the point of dispatch. Provided the original items are received back at PAT within 28 days from the date upon which the Returns Authorisation Number is issued and PAT agree following testing / inspection that these are defective, a credit note will be issued.

4 Services: PAT warrants that it will carry out the Services with reasonable care and skill. If PAT is shown to be in breach of this warranty in respect of particular Services it shall at its option and cost either re-provide those Services or refund any sums already paid in respect of those Services.

5 PAT does not exclude or limit its liability in negligence for death or personal injury, or for fraud or wilful default, or otherwise to the extent that any exclusion or limitation of its liability is void, prohibited or unenforceable by law.

6 Subject to Clauses 6.1 - 6.5, all representations, warranties and conditions implied by trade custom, course of dealing, statute, common law or otherwise are excluded to the fullest extent permitted by law.

7 Subject to Clause 6.5, in no circumstances shall PAT be liable to the Purchaser, in contract, at law or otherwise, for any incidental or consequential loss including, without limitation, any loss of profit, business, revenue, goodwill or anticipated savings or for any special, exemplary or consequential damages or other financial loss whatsoever arising out of or in connection with the Contract or the supply of the Goods or Services or their use or resale (if applicable) by the Purchaser.

8 If notwithstanding the provisions of these Conditions PAT is found liable for any loss suffered by the Purchaser arising in any way out of or in connection with the Contract or the supply of any Goods or Services that liability shall in no event exceed the price paid for such Goods or Services.

9 The parties hereby confirm that notwithstanding any other provision of the Contract or these Conditions, the Contract shall not and shall not purport to confer on any third party the right to enforce any term of the Contract.